

TECH TIPS

APPLICATION TECHNIQUES

Spray Pattern Overlap

Custom painting requires a good understanding of the basics. It demands attention to detail and a working knowledge of sound application techniques. The following is a brief description of both a 50% and 75% spray pattern overlap.

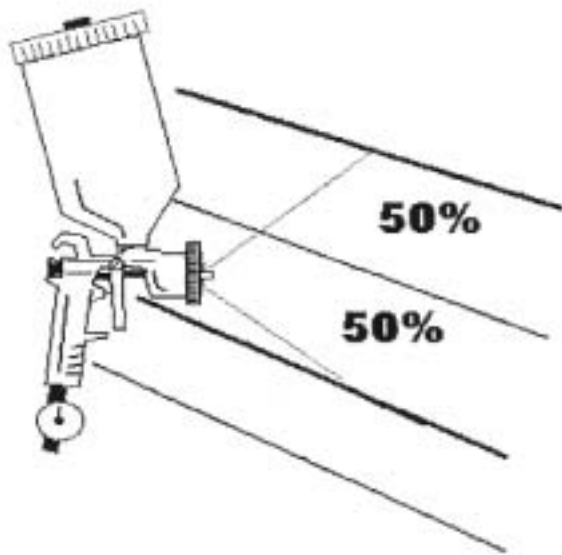

50% Overlap

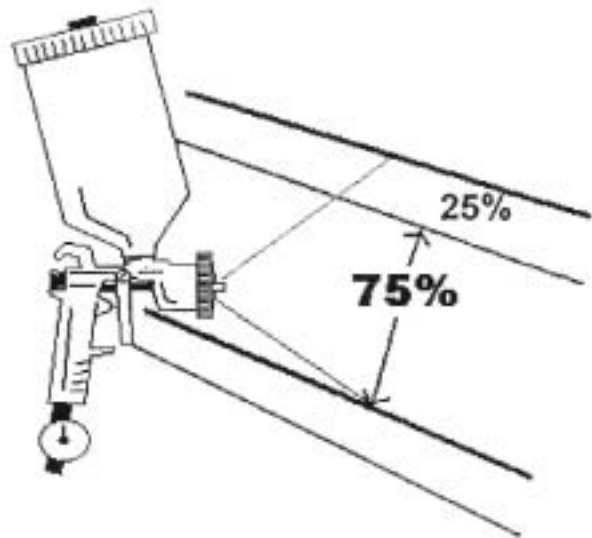

75% Overlap

- Measure spray gun pattern width, do not guess.
- Adjust spray gun for pattern consistency.
- Restrict amount of fluid being delivered when using 75% overlap to avoid runs and sags.
- 75% overlap generally used for Pearls and the first 2 to 3 coats of Kandys.

TECH TIPS

URETHANES/POLYURETHANES

Flash Between Coats

The times allowed between coats of Urethanes and Polyurethanes are critical for the success of a custom paint job. Actual times vary depending on temperature, air flow and humidity. One of the safest ways to determine when a finish is ready for the next coat is by the “string” method. This method is as follows:

- Find area on masking tape closest to “wettest” point of sprayed finish.
- Press finger into finish and lift up approximately one inch.
- Look for fine hair-like strings pulling up with finger.
- Continue this process using a different spot each time until finish stops “stringing”.
- Once finish still feels sticky, but does not “string”, it is ready for next coat.
- Do not allow House of Kolor Urethanes or Polyurethanes to completely dry to touch. If finish completely dries to touch, finish must not be recoated for 12 hours or lifting may occur.

